

VALCOM HANDSFREE TALKBACK PAGING SYSTEM DESIGN/INFORMATION

INTRODUCTION

These instructions provide the basic information required to properly install a Valcom Handsfree Talkback Intercom or Paging System.

Valcom Handsfree Talkback Equipment may be used with any 1A2, Electronic Key, PABX Telephone System, or with one or more dedicated single line telephone(s).

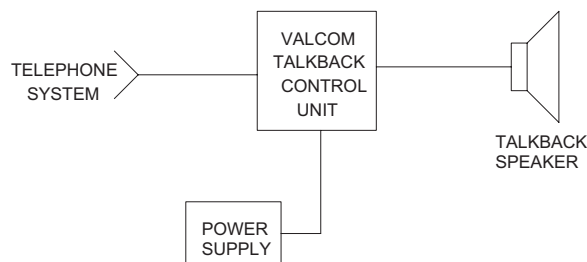

FIGURE 1
TALKBACK SYSTEM BLOCK DIAGRAM

SYSTEM OVERVIEW

Purpose

- Provides telephone system accessed paging with handsfree reply.

Applications

- Electronic Key System Handsfree Paging.
- PABX Handsfree Paging.
- Centrex/Essex Handsfree Intercom/Paging in conjunction with a Station level Page Adapter.
- Stand Alone Handsfree Paging Systems.
- 1A2 Handsfree Intercom.

Features

- 1, 3, 6, 9, 20, 24, 48, 72, and 96 zone systems are available.
- Talkback control units also support one-way speakers.
- Standard 22 or 24 AWG twisted pair telephone wire used for speakers.
- Existing Cat 3 or 5 twisted house cable or feed cable may be used without introducing crosstalk.
- One-way all call to all speakers available.
- One-way and talkback paging may be mixed on the same zone. Each talkback zone may include a talkback and up to 40 one-way amplified speakers.
- Ceiling, wall, horn, desktop, and explosion proof paging speakers available.
- Alert tone on page access (optional on some units).
- 15 second repeated alert tone (optional on some units).
- No alert tone on all call.
- Additional features are available on individual units. Check appropriate installation practice for information.

Access Methods

- Electronic Key System or PABX loop trunk port (trunk circuit required).
- Stand alone systems via dedicated single line telephone instruments.
- 1A2 line button (line card not required on most units).

Table 1. Capacity

		MODEL								
		V-9941A	V-2003AHF	V-2006AHF	V-1109RTHF	V-2920	V-2924A	V-2924A + one V-2925A	V-2924A + two V-2925As	V-2924A + three V-2925As
Features	# Zones	1	3	6	9	20	24	48	72	96
	Background Music	●	●	●	●	●	●	●	●	●
	All Call	●	●	●	●	●	●	●	●	●
	Night Ring/Time Clock Tones		●	●			●	●	●	●
	Group Call			●			●	●	●	●
	Power Supply Built In		●	●		●				
	Battery Back-up Input		●	●		●	●	●	●	●
	Emergency Page Override		●	●			●	●	●	●
Access	Loop Start Trunk	●	●	●	●	●	●	●	●	●
	Ground Start Trunk		●	●			●	●	●	●
	Page Port	■	■	■						
	Power Units	-6	+10	+30	-6	0	0	0	0	0

■ Selected Phone Systems
 - Consumes Power
 + Provides Power
 ** Up to 6 fully expanded
 V-2924A units may be connected for common All Call for a total of 576 zones

Reply Distance

The distance you can be away from a speaker and still have good talkback depends on the type of speaker and the ambient noise level. In a typical office environment, a wall speaker will cover 600 square feet (Talkback from 25') and a ceiling speaker will cover 250 square feet (Talkback from 10').

V-2924A: 17.50"H x 10.31"W x 3.06"D
 (44.45cm x 26.19cm x 7.77cm)
 15 lbs. (6.8 kg)
 V-2925A: 17.50"H x 8/37"W x 3.06"D
 (44.45cm x 21.26cm x 7.77cm)
 13.5 lbs. (6.08 kg)

REMEMBER: *The speaker is no better than your ears. If you cannot carry on a conversation at normal voice levels over the required talkback distance, then talkback page equipment will not function in a satisfactory manner.*

When mounting a talkback speaker: *The speaker should be as close as possible to the area where talkback is desired. It should not be mounted close to, or pointed at, noise production equipment such as fans, air conditioners, machinery, or compressors.*

Dimensions/Weight

V-9941A: 8.25"H x 4.65"W x 2.30"D
 (20.95cm x 11.81cm x 5.84cm)
 1.5 lbs. (.68 kg)
 V-2003AHF: 7.15"H x 10.0"W x 3.0"D
 (18.16 cm x 25.4cm x 7.62cm)
 5.6 lbs. (2.54 kg)
 V-2006AHF: 10.90"H x 13.0"W x 2.70"D
 (27.68cm x 33.02cm x 6.85cm)
 6.2 lbs. (2.81 kg)
 V-2920: 8.55"H x 11.0"W x 2.35"D
 (21.71cm x 27.94cm x 5.96cm)
 6.7 lbs. (3.04 kg)

Limitations

- Two talkback speakers* maximum per zone (unless V-9922A Talkback Speaker Selection Units are utilized).
- Two talkback* plus 40 one-way amplified speakers maximum per zone when mixing talkback and one-way paging.
- 800 feet maximum cable length to speaker. NOTE: Do not split pairs to speakers.
- Do not use talkback in noisy areas (80 dB or greater).

* The V-2924A and V-2925A can support 1 talkback speaker per zone.

Speaker Power Requirements

- Valcom Talkback Speakers do not require power.

Valcom Power Units

Each page control/interface, one-way speaker and peripheral device has been assigned a Valcom power unit (VPU) value. Each product either provides a power output (+) or consumes power (-). Products

that neither require, nor provide, power are indicated by a VPU of zero (0).

After you have chosen the page control interface, speakers and accessories for your application, simply add up all of the Valcom Power Units. If you come out even or have power left over, your paging system is complete. However, if you come out with more VPUs required than provided, you will need additional power.

The additional power required will be provided by adding one or more Valcom power supplies as listed in table 2.

Table 2 - Valcom Power Supplies

Part #	Voltage	Maximum Current	Valcom Power Units
VP-324	-24VDC	250mA	+6
VP-624B	-24VDC	600 mA	+12
VP-1124	-24VDC	1.0 amp	+20
VP-2024	-24VDC	1.0 amp	+20
VP-2124A	-24VDC	2.0 amp	+40
VP-4024C	-24VDC	4.0 amp	+80
VP-4124	-24VDC	4.0 amp	+80
VP-6124	-24VDC	6.0 amp	+120
VP-12124	-24VDC	12.0 amp	+240

There are several cases when more than one power supply will be required:

- When the power required exceeds the maximum output of the power supplies available: Add additional supplies as required.
- In large systems or systems with many one-way horn speakers: Locate separate power supplies near groups of speakers. Refer to the Valcom Wire Gauge Guide for guidelines concerning maximum allowable distances for power runs.
- When the paging system is in several buildings, or on several floors of a single building: Locate a power supply in each building, or on each floor, that contains equipment requiring power.

Environment

Control Units:
 Temperature: 0 to +40 Degrees C
 Humidity: 0-85% non-condensing

Inside Speakers:
 Temperature: -20 to +55 Degrees C
 Humidity: 0-95% non-condensing

Horn Speakers:
 Temperature: -20 to +55 Degrees C
 Humidity: 0-95% non-condensing

E-Key, PABX, or Dedicated Single Line Telephone Set

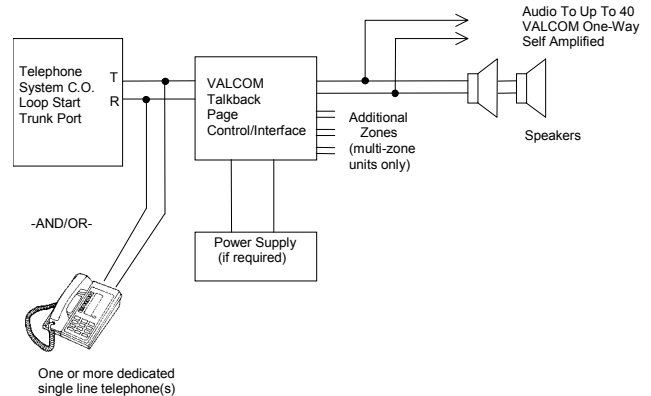

Block Diagram of Loop Start Trunk Port And/Or Single Line Telephone Access of a Valcom Talkback Page Control/Interface
 FIGURE 2

To provide handsfree answerback paging on 1A2, E-Key, or PABX Systems, you will need a talkback control, talkback speakers, and a power supply.

The speakers may be any of Valcom's 45 ohm Talkback Speakers. In most cases, if the control unit requires a power supply, the VP-624B will be adequate. Larger power supplies may be required if one-way speakers or horns are utilized.

Access will be from a C.O. line key on E-Key Systems, from a loop trunk port on PABXs, or from Tip and Ring on one or more dedicated single line sets. A trunk circuit will be required on a PABX or E-Key system.

Page Port Access

In general, telephone system page ports are not capable of passing audio in both directions and, therefore, are suitable for one-way paging only. In the case of bi-directional page ports, contact Technical Support for assistance in choosing the appropriate talkback page control/interface.

Station Level Paging

Station level access to talkback paging systems may be accomplished in certain instances by utilizing the Valcom V-9940 Station Level Page Adapter. Due to

the nature of talkback paging with station level access from various C.O. lines or PABX/PBX stations, it is advisable to contact Technical Support prior to configuring your system.

Mixing Talkback and One-Way Paging

When using a Talkback Control Unit, one-way and talkback zones may be mixed on the same control unit. The outgoing page on a talkback zone may also be expanded by adding one-way speakers.

To make a zone one-way, simply add a V-1092 volume control and Valcom one-way amplified speakers to that zone (maximum 40 per zone).

To expand the outgoing page on a talkback zone, wire one-way amplified speakers in parallel with the talkback speakers on that zone (maximum 40 per zone). Of course, when you do this you still will only be receiving talkback from the 45 ohm talkback speakers on the zone.

NOTE: When using one-way amplified speaker assemblies on a talkback control unit, a V-1092 Volume Control or a V-1094A Page Port Preamp may be used to attenuate the high level talkback audio level prior its appearance at the audio input of the one-way speakers (talkback audio is substantially higher in level in comparison to one-way audio).

Talkback Speakers

Valcom talkback speakers are available in the following styles:

8" Ceiling Speaker	V-1060A*
Wall Speaker (black vinyl)	V-1061-BK
Wall Speaker (white vinyl)	V-1061-W
Wall Speaker (lt. brown open weave grille)	V-1062A*
Wall Speaker (dark brown cloth grille)	V-1063A
Corner Speaker (lt. brown open weave grille)	V-1064A*
Corner Speaker (dark brown cloth grille)	V-1065A
Bi-directional Corridor Speaker (lt. brown open weave grille)	V-1066A*
Bi-directional Corridor Speaker (dark brown cloth grille)	V-1067A
Desk Top Speaker With Volume Control	V-762
Desk Top Speaker	V-764

With Volume Control and Push Button	
Talkback Slimline Wall Speaker (Black)	V-1046-BK
Talkback Slimline Wall Speaker (White)	V-1046-W
Talkback Slimline Wall Speaker (Brown)	V-1046-BR
Talkback Slimline Wall Speaker (Gray)	V-1046-GY
Talkback Horn	V-1048C*
Talkback Marine Horn	V-1048M
Explosion Proof Horn	V-1069A
Surface Mount Door Plate Speaker With "Call" Button	V-1074
Brass Flush Mount Door Plate Speaker With "Call" Button	V-1072A-BRASS*
Stainless Steel Flush Mount Door Plate Speaker with "Call" Button	V-1072A-ST*
Vandal-Proof Doorplate Speaker With "Call" Button	V-1073
Flex Horn (Beige)	V-1090-BG
Flex Horn (White)	V-1090-W
Lay-In Talkback Speaker	V-9062
2" Multi-Purpose Speaker	V-9912

*Available in a "B" version (i.e. V-1060B) with integrated LED indicator.

SYSTEM INSTALLATION

General

For specific wiring information, consult the installation practice enclosed with the actual equipment you are using.

Precautions

Locate the Valcom equipment or cabling at least 18" away from power supplies, electrical panels, or any equipment that generates electrical noise. Additionally, locate the Valcom equipment within 6' of the Valcom or 1A2 power supply used to power the unit(s).

Mounting

The control equipment should be installed at the main distribution frame with the telephone system common equipment.

Cabling

Standard 22 or 24 AWG twisted pair telephone wire may be used for the speakers. Talkback speakers

require 1 pair (2 pairs when using speakers with LEDs or "doorplate speaker assemblies"). One-way amplified speakers require 2 pairs (Refer to the One-Way Paging VSP).

MAXIMUM CABLE LENGTH TO TALKBACK SPEAKERS IS 800 FEET

DO NOT SPLIT PAIRS

Grounding

For proper operation, ground of the power supply must be connected to a reliable ground.

CAUTION: *Using an electrical ground may put noise on the talkback.*

High Power Amplifiers

In many cases an existing high power amplifier may be connected to a zone output of the control unit for one-way paging. Simply insert a V-1092 volume control and connect the zone audio output to the auxiliary input of the amplifier.

NOTE: *YOU CANNOT INCREASE THE NUMBER OF TALKBACK SPEAKERS IN A ZONE THROUGH USE OF A HIGH POWER TALKBACK AMPLIFIER.*

Volume Adjustments

All talkback control units have two volume controls:

1. Speaker to telephone. (Receive) Adjust this control for minimum background noise. Between 1/4 and 1/2 is typical.
2. Telephone to speaker. (Transmit) Adjust this control to provide the desired level of outgoing page.

If background music is provided or one-way amplified speakers are being used, the controls MUST be adjusted in the following order:

1. Speaker to phone
2. Phone to speaker
3. All call level
4. Music level
5. Individual controls on one-way speakers

Inhibit (Speaker Cancel)

Inhibit is an option that may be used with 1A2 Key Systems or with "A-lead" single line telephones. It automatically turns off a speaker when the called party picks up their handset and presses the intercom button to have a handset to handset call. To wire the inhibit option, you must place 10K ohm resistors (included with equipment) in series with the "A" leads from each telephone's intercom button, or in the

case of dedicated single line set, in series with the "A" leads from each telephone. The other side of these resistors will be connected together and brought to the inhibit lead of the control unit.

REMEMBER: A resistor will be required for each telephone. If feed cables to several phones are used, the resistors must be placed at the telephone or the remote terminal. Contact Technical Support for additional information.

SYSTEM OPERATION

Circuit Description

Each Valcom Handsfree Control Unit contains access circuitry, voice switching, and talkback circuitry. The multizone units also contain dial select circuitry. All talkback control units are designed for use with 45 ohm speakers. These may be desktop speakers for intercom applications; or ceiling speakers, wall speakers, or horns for paging applications. In addition to the control unit and speakers, a talkback system may require a -24VDC power supply.

Talkback control units generally will be connected to a key button of a 1A2 System (line card required when using the V-9941A, V-2003AHF or the V-2006AHF), a line key of an Electronic Key System (line card required) or a loop trunk port of a PABX (trunk card required).

When accessed by the appropriate method, the paging party will immediately be connected to the speaker (single zone unit), or will receive dial tone (multizone unit). In multizone applications, the paging party will then dial the zone desired, page, and receive the reply.

In 1A2 or dedicated stand alone "A-lead type" telephone applications, the called party has the option to pick up their handset, depress the intercom button (in the case of 1A2 equipment), and speak handset to handset to the calling party. If the inhibit option is wired [Section *Inhibit (Speaker Cancel)*], the called speaker will automatically turn off when a handset to handset conversation is initiated.

Instructions to User

Valcom talkback equipment contains voice switching circuitry. This means only one party may be talking at a time. The voice switch is controlled by the telephone end. If the calling party is quiet, they can listen to the speaker.

As soon as the calling party speaks, the voice will page out of the speaker. If someone at the speaker is talking, the calling party's voice will override them.

In order to achieve maximum performance from their talkback system, the user should be given the following instructions:

- A) The calling party should speak directly into the telephone mouthpiece and should avoid speaking too softly.
- B) The called party must wait (approximately 1/2 second) before responding to the calling party.

NOTES

- V-2003AHF: The V-2003A + V-9953 is equivalent and may be used in place of a V-2003AHF.
- V-2006AHF: The V-2006A + V-9956 is equivalent and may be used in place of a V-2006AHF.
- V-2924A: The V-2924A provides 24 zones. Up to 3 Expansion Units (V-2925A) may be added to the base V-2924A unit to provide up to 96 zones of paging. Up to 6 fully expanded V-2924A units may be connected for common All Call for a total of 576 zones.

TECHNICAL ASSISTANCE

Refer to the installation practices for the equipment being used for troubleshooting information and procedures. Technical assistance is available from the factory. When calling, you should have a VOM, a telephone test set, and several clip leads available and be calling from the job site. Call (540) 427-3900 and ask for Technical Support, or (540) 427-6000 for Valcom 24-hour Automated Support or visit our website at <http://www.valcom.com>.

Valcom equipment is not field repairable. Valcom, Inc. maintains service facilities in Roanoke, VA. Should repairs be necessary, attach a tag to the unit clearly stating company name, address, phone number, contact person, and the nature of the problem. Send the unit to:

**Valcom, Inc.
Repair & Return Dept.
5614 Hollins Road
Roanoke, VA 24019-5056**

VALCOM LIMITED WARRANTY

Valcom, Inc. warrants its products to be free from defects in materials and workmanship under conditions of normal use and service for a period of one year from the date of shipment. The obligation under this warranty shall be limited to the replacement, repair or refund of any such defective device within the warranty period, provided that:

1. inspection by Valcom, Inc. indicates the validity of the claim,
2. the defect is not the result of damage, misuse, or negligence after the original shipment.
3. the product has not been altered in any way or repaired by others and that factory sealed units are unopened (A service charge plus parts and labor will be applied to units defaced or physically damaged),
4. freight charges for the return of products to Valcom are prepaid,
5. all units 'out of warranty' are subject to a service charge. The service charge will cover minor repairs (Major repairs will be subject to additional charges for parts and labor).

This warranty is in lieu of and excludes all other warranties, expressed or implied, and in no event shall Valcom, Inc. be liable for any anticipated profits, consequential damages, loss of time or other losses incurred by the buyer in connection with the purchase, operation, or use of the product.

This warranty specifically excludes damage incurred in shipment. In the event a product is received in damaged condition, the carrier should be notified immediately. Claims for such damage should be filed with the carrier involved in accordance with the F.O.B. point.

Headquarters:
Valcom, Inc.
1111 Industry Avenue
Roanoke, VA 24013
Phone: (540) 427-3900
FAX: (540) 427-3517

In Canada
CMX Corporation
35 Van Kirk Drive #11 and 12
Brampton, Ontario L7A1A5
Phone: (905) 456-1072
FAX: (905) 456-2269

